

# Physics Question Paper 2019 Set-2

---

## General Instructions:

1. All questions are compulsory. There are 27 questions in all.
2. This question paper has four sections: Section A, Section B, Section C and Section D.
3. Section A contains five questions of one mark each, Section B contains seven questions of two marks each, Section C contains twelve questions of three marks each, and Section D contains three questions of five marks each.
4. There is no overall choice. However, internal choices have been provided in two questions of one mark, two questions of two marks, four questions of three marks and three questions of five marks weightage. You have to attempt only one of the choices in such questions.
5. You may use the following values of physical constants wherever necessary.

$$c = 3 \times 10^8 \text{ m/s}$$

$$h = 6.63 \times 10^{-34} \text{ Js}$$

$$e = 1.6 \times 10^{-19} \text{ C}$$

$$\mu_0 = 4\pi \times 10^{-7} \text{ T m A}^{-1}$$

$$\epsilon_0 = 8.854 \times 10^{-12} \text{ C}^2 \text{ N}^{-1} \text{ m}^{-2}$$

$$\frac{1}{4\pi\epsilon_0} = 9 \times 10^9 \text{ N m}^2 \text{ C}^{-2}$$

$$m_e = 9.1 \times 10^{-31} \text{ kg}$$

$$\text{mass of neutron} = 1.675 \times 10^{-27} \text{ kg}$$

$$\text{mass of proton} = 1.673 \times 10^{-27} \text{ kg}$$

$$\text{Avogadro's number} = 6.023 \times 10^{23} \text{ per gram mole}$$

$$\text{Boltzmann constant} = 1.38 \times 10^{-23} \text{ JK}^{-1}$$

---



### Question 1

Define the term "Threshold frequency", in the context of photoelectric emission.

OR

Define the term "Intensity" in the photon picture of electromagnetic radiation.

### SOLUTION:

For a given Photosensitive material, there is a certain minimum cut off frequency at which Photoelectric emission is possible is called Threshold frequency, i.e. At this frequency just emission of photoelectrons happens without giving them any kind of additional energy. Higher the work function of the material, greater is the Threshold frequency.

See the figure below of two different metals having different Threshold Frequency.

OR

The intensity  $I$ , is defined as the total amount of energy falling on a given surface/Region per unit time ' $t$ ' and per unit area ' $A$ '.

If the total energy emitted =  $nh\nu$

$$\text{Then, } I = \frac{nh\nu}{At}$$

### Question 2

When unpolarized light is incident on the interface separating the rarer medium and the denser medium, Brewster angle is found to be  $60^\circ$ . Determine the refractive index of the denser medium.

### SOLUTION:

The relation between refractive index and Brewster's angle is,  $\mu = \tan \theta_B$  (Assuming rarer medium as Air)

$$\mu = \tan \theta_B \quad [\text{Where, } \theta_B = \text{Brewster's angle}]$$

$$\mu = \tan 60^\circ = \sqrt{3}$$

So, the refractive index of the denser medium is  $\sqrt{3}$

### Question 3

In skywave mode of propagation, why is the frequency range of transmitting signals restricted to less than 30 MHz?

OR

**On what factors does the range of coverage in ground wave propagation depend?**

**SOLUTION:**

In skywave mode of propagation, the frequency range of transmitting signals is restricted to less than 30 MHz, because it is the maximum frequency below which the signals can be transmitted from one point to another point via reflection from ionosphere. Above this frequency, the signals will be transmitted through the ionosphere and are not reflected back.

OR

The ground wave propagation is preferred usually for long distance communication using frequencies below 3 MHz. The range of coverage of ground wave propagation depends on transmitted power and frequency.

**Question 4**

**When a potential difference is applied across the ends of a conductor, how is the drift velocity of the electrons related to the relaxation time?**

**SOLUTION:**

Let potential difference ' $V$ ' is applied across a conductor of length ' $L$ ', then  $E = \frac{V}{L}$

The relation between drift velocity and relaxation time  $\Rightarrow v_d = -\frac{eV}{mL}\tau$

Where,  $v_d$  is the drift velocity  
 $e$  charge on an electron  
 $V$  is the Voltage applied  
 $L$  is the length of the conductor  
 $m$  is mass of an electron  
 $\tau$  is the relaxation time

**Question 5**

**Draw the equipotential surfaces due to an isolated point charge.**

**SOLUTION:**

For a negative charge, electric field lines are towards the charge. And for a positive charge, electric field lines are away from the charge. The following figure shows the equipotential surfaces due to an isolated positive and negative charge:

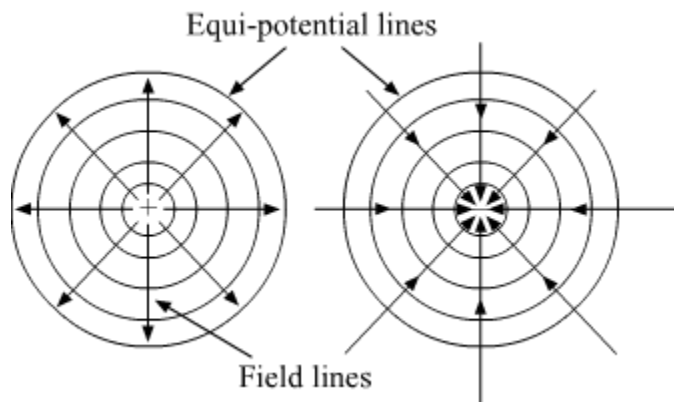

### Question 6

Explain with the help of Einstein's photo electric equation any two observed features in photoelectric effect which cannot be explained by wave theory.

### SOLUTION:

These are the two features of Photoelectric effect which can not be explained by wave theory but can be explained through Einstein's photoelectric equation:

1. For a given metal and a given frequency of incident radiation, the number of photoelectrons ejected per second is directly proportional to the intensity of the incident light.
2. For a given metal, there exists a certain minimum frequency of the incident radiation below which no emission of photoelectrons takes place. This frequency is called the threshold frequency.

### Question 7

A deuteron and an alpha particle having same momentum are in turn allowed to pass

through a magnetic field  $\vec{B}$ , acting normal to the direction of motion of the particles. Calculate the ratio of the radii of the circular paths described by them.

### SOLUTION:

Mass of deuteron = 2 units =  $m_d$   
 Charge on deuteron = 1 unit =  $q_d$   
 Mass of alpha particle = 4 units =  $m_\alpha$   
 Charge on alpha particle = 2 units =  $q_\alpha$

Radius of circular path  $R = \frac{mv}{qB}$

$$\frac{\text{Radius of deuteron}}{\text{Radius of alpha particle}} = \frac{R_d}{R_\alpha}$$

$$\Rightarrow \frac{m_d v_d}{q_d \cdot B} \cdot \frac{q_\alpha \cdot B}{m_\alpha v_\alpha}$$

Since the momentum of the alpha particle and deuteron are same.

$$\therefore m_d \cdot v_d = m_\alpha \cdot v_\alpha$$

$$\Rightarrow \frac{R_d}{R_\alpha} = \frac{m_d \cdot v_d \cdot q_\alpha \cdot B}{q_d \cdot B \cdot m_\alpha \cdot v_\alpha} = \frac{q_\alpha}{q_d} = \frac{2}{1} = 2$$

### Question 8

Two bulbs are rated  $(P_1, V)$  and  $(P_2, V)$ . If they are connected (i) in series and (ii) in parallel across a supply  $V$ , find the power dissipated in the two combinations in terms of  $P_1$  and  $P_2$ .

### SOLUTION:

Given Bulbs are rated as  $(P_1, V)$  &  $(P_2, V)$  respectively.

The resistance of 1st bulb,  $R_1 = \frac{V^2}{P_1}$

The resistance of 2nd Bulb,  $R_2 = \frac{V^2}{P_2}$

(i) When Both are connected in Series with a power supply of voltage  $V$ .

As both the bulbs are in series connection hence both will have the same amount of current flowing through them.

$$i = \frac{V}{R_1 + R_2} = \frac{V}{\frac{V^2}{P_1} + \frac{V^2}{P_2}} = \frac{1}{V} \left( \frac{P_1 P_2}{P_1 + P_2} \right)$$

Power dissipated in the circuit,

$$P_d = i^2 (R_1 + R_2) = \frac{1}{V^2} \left( \frac{P_1 P_2}{P_1 + P_2} \right)^2 \left( \frac{V^2}{P_1} + \frac{V^2}{P_2} \right)$$

$$P_d = \frac{P_1 P_2}{P_1 + P_2}$$

(ii) When both are connected in parallel

In this case, Both bulbs will get the same voltage supply.

Hence Power dissipated,

$$P_d = \frac{V^2}{R_1} + \frac{V^2}{R_2} = V^2 \left( \frac{P_1}{V^2} + \frac{P_2}{V^2} \right)$$

$$P_d = P_1 + P_2$$

### Question 9

Calculate the radius of curvature of an equi-concave lens of refractive index 1.5, when it is kept in a medium of refractive index 1.4, to have a power of -5D?

OR

An equilateral glass prism has a refractive index 1.6 in the air. Calculate the angle of minimum deviation of the prism, when kept in a medium of refractive index  $4\sqrt{2}/5$ .

### SOLUTION:

Using lens maker formulae for given equi-concave lens,

$$\frac{1}{f} = \left( \frac{n_2}{n_1} - 1 \right) \left( \frac{1}{-R} - \frac{1}{R} \right)$$

$$\Rightarrow \frac{1}{f} = \left( \frac{n_2}{n_1} - 1 \right) \left( -\frac{2}{R} \right) \dots(1)$$

Where  $n_2$  and  $n_1$  are the refractive index of the lens and medium, respectively. where  $n_2 = 1.5$  &  $n_1 = 1.4$

Power of lens = -5D (Given)

$$\text{Focal length, } f = \frac{1}{-5} \times 100 = -20\text{cm}$$

Putting all the values in equation 1, we get,

$$\Rightarrow \frac{1}{-20} = \left( \frac{1.5}{1.4} - 1 \right) \left( -\frac{2}{R} \right)$$

$$\Rightarrow \frac{1}{20} = \left( \frac{0.1}{1.4} \right) \left( \frac{2}{R} \right)$$

$$\Rightarrow R = \frac{4}{1.4} = 2.86\text{cm}$$

OR

When the prism is kept in another medium. we have to take the refractive index of the prism with respect to the given medium:

$$\mu_{\text{prism}}^{\text{medium}} = \frac{\mu_{\text{prism}}}{\mu_{\text{medium}}} = \frac{\sin\left[\left(\frac{A+D_m}{2}\right)\right]}{\sin\left(\frac{A}{2}\right)}$$

$$\frac{1.6}{\frac{4\sqrt{2}}{5}} = \frac{\sin\left[\left(\frac{60^\circ+D_m}{2}\right)\right]}{\sin\left(\frac{60^\circ}{2}\right)}$$

$$\sqrt{2} = \frac{\sin\left[\left(\frac{60^\circ+D_m}{2}\right)\right]}{\frac{1}{2}}$$

$$\sin^{-1}\left(\frac{1}{\sqrt{2}}\right) = \left(\frac{60^\circ+D_m}{2}\right)$$

$$90^\circ = 60^\circ + D_m$$

$$D_m = 30^\circ$$

### Question 10

State Bohr's quantization condition of angular momentum. Calculate the shortest wavelength of the Bracket series and state to which part of the electromagnetic spectrum does it belong.



OR

Calculate the orbital period of the electron in the first excited state of hydrogen atom.

**SOLUTION:**

According to Bohr's quantisation, the electrons revolve around the nucleus only in those orbits for which the angular momentum is the integral multiple of

$$\frac{h}{2\pi}$$

$$L = \frac{nh}{2\pi}$$

For Bracket series  $n_2 = \infty$ ,

$$\frac{1}{\lambda} = R_H Z^2 \left\{ \frac{1}{4^2} - \frac{1}{\infty} \right\}$$

$$\frac{1}{\lambda} = \frac{R_H}{16}$$

$$\lambda = \frac{16}{R_H} = 14.58 \times 10^{-7} \text{ m}$$

This wavelength belongs to the Infra-red region.

OR

$$r = 0.53 \frac{n^2}{z} \times 10^{-10} \text{ m}$$

For first excited state  $n = 2$

$$r = 0.53 \frac{2^2}{1} \times 10^{-10}$$

$$r = 2.12 \times 10^{-10} \text{ m}$$

$$v = v_0 \times \frac{Z}{n} \text{ m/s}$$

$$v = 2.188 \times 10^6 \times \frac{Z}{n} \text{ m/s}$$

For first excited state,  $n = 2$ ,  $Z = 1$  for hydrogen atom

$$\therefore v = 2.188 \times 10^6 \times \frac{1}{2} \text{ m/s}$$

$$\Rightarrow v = 1.094 \times 10^6 \text{ m/s}$$

$$\therefore \text{Orbital period} = \frac{2\pi r}{v} = \frac{2 \times 3.14 \times 2.12 \times 10^{-10}}{1.094 \times 10^6}$$

$$\Rightarrow \text{Orbital period} = 1.22 \times 10^{-15} \text{ sec}$$



### Question 11

(a) Plot a graph showing variation of deBroglie wavelength ( $\lambda$ ) associated with a charged particle of mass  $m$ , versus  $\sqrt{V}$ , where  $V$  is the accelerating potential.

(b) An electron, a proton and an alpha particle have the same kinetic energy. Which one has the shortest wavelength?

### SOLUTION:

(a) According to de broglie equation :

$$\lambda = \frac{h}{mv} = \frac{h}{P}$$

$$\lambda = \frac{h}{\sqrt{2m(\text{K.E})}}$$

$$\therefore \text{K.E} = eV$$

$$\lambda = \frac{K}{\sqrt{V}}, y = \frac{K}{x} \text{ Where } K \text{ is a constant, } K = \frac{h}{\sqrt{2me}}$$

A graph is drawn below to show the relation between  $\lambda$  and  $\sqrt{V}$ :

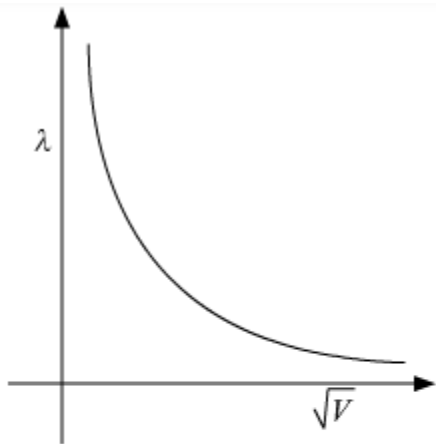

It is a Rectangular Hyperbola.

(b) We know that

$$\text{K.E} = \frac{P^2}{2m}$$

From this,

$$P = \sqrt{2m(\text{K.E})} \text{ equation (1)}$$

According to De Broglie equation:-

$$\lambda = \frac{h}{mv} = \frac{h}{P}$$

$$\lambda = \frac{h}{\sqrt{2m(\text{K.E})}} \text{ from equation (1)}$$

If electron, Proton and the alpha particle have the same kinetic energy then,  $\lambda \propto \frac{1}{\sqrt{m}}$

We know that  $m_\alpha > m_p > m_e$

Therefore,  $\lambda_e > \lambda_p > \lambda_\alpha$

### Question 12

**Why a signal transmitted from a TV tower cannot be received beyond a certain distance? Write the expression for the optimum separation between the receiving and the transmitting antenna.**

### SOLUTION:

Signal transmitted from a TV tower cannot be received beyond a certain distance because of the curvature of the earth.

Expression for the optimum separation between the receiving and transmitting antenna:

$$d = \sqrt{2hR}$$

*d*: Optimum separation.

*h*: Height of the antenna

*R*: Radius of the curvature of Earth.

### Question 13

**(a) State the underlying principle of a moving coil galvanometer.**

**(b) Give two reasons to explain why a galvanometer cannot as such be used to measure the value of the current in a given circuit.**

**(c) Define the terms : (i) voltage sensitivity and (ii) current sensitivity of a galvanometer.**

### SOLUTION:

(a) Principle: Torque acts on a current carrying coil suspended in the uniform magnetic field. Due to this, the coil rotates. Hence, the deflection in the coil of a moving coil galvanometer is directly proportional to the current flowing in the coil.

(b) A galvanometer cannot be used as such to measure current due to following two reasons.

(i) A galvanometer has a finite large resistance and is connected in series in the circuit, so it will increase the resistance of the circuit and hence change the value of current in the circuit.

(ii) A galvanometer is a very sensitive device, it gives a full-scale deflection for the current of the order of microampere, hence if connected as such it will not measure the current of the order of ampere.



(c) (i) Voltage sensitivity: It is defined on the deflection of the coil when a unit potential difference is applied across the two terminals of the Galvanometer.

Voltage Sensitivity,  $V_s = \frac{\theta}{IR}$ , Where R is the resistance of galvanometer.

(ii) Current sensitivity: It is defined as the deflection of the coil when a unit current flows through it.

Current Sensitivity,  $I_s = \frac{\theta}{I}$

### Question 14

(a) Define mutual inductance and write its S.I. unit.

(b) A square loop of side 'a' carrying a current  $I_2$  is kept at distance x from an infinitely long straight wire carrying a current  $I_1$  as shown in the figure. Obtain the expression for the resultant force acting on the loop.

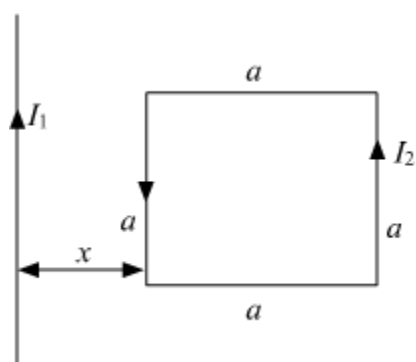

### SOLUTION:

(a) Mutual inductance is where the magnetic field generated by a coil of wire induces voltage in an adjacent coil of wire. A transformer is a device constructed of two or more coils in close proximity to each other, with the express purpose of creating a condition of mutual inductance between the coils. Its SI unit is : Wb/A

(b)

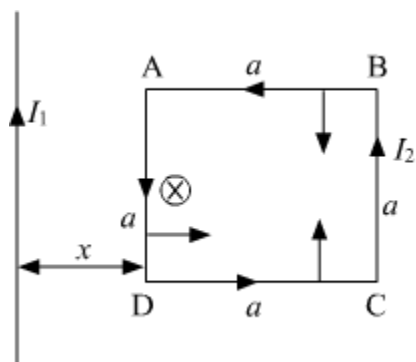

According to the Right-hand screw rule, the magnetic field will be into the plane across the loop.

### Force on length AD:-

$$F = BIl$$

$$F_1 = \frac{\mu_0 I_1 I_2 a}{2\pi x} \text{ (Towards Right)}$$

Force on length BC:-

$$F = BIl$$

$$F_2 = \frac{\mu_0 I_1 I_2 a}{2\pi(x+a)} \text{ (Towards Left)}$$

Force on AB and CD will be equal and opposite .

Hence, they'll cancel out.

Force on the loop:-

$$F_{\text{Net}} = F_1 - F_2$$

$$= \frac{\mu_0 I_1 I_2 a}{2\pi} \left[ \frac{1}{x} - \frac{1}{(x+a)} \right]$$

$$F_{\text{Net}} = \frac{\mu_0 I_1 I_2 a}{2\pi} \left[ \frac{x+a-x}{(x+a)x} \right] = \frac{\mu_0 I_1 I_2 a^2}{2\pi(x+a)x}$$

$$F_{\text{Net}} = \frac{\mu_0 I_1 I_2 a^2}{2\pi x(x+a)} \text{ (Towards left)}$$

### Question 15

(a) Draw equipotential surfaces corresponding to the electric field that uniformly increases in magnitude along with the z-directions.

(b) Two charges  $-q$  and  $+q$  are located at points  $(0, 0, -a)$  and  $(0, 0, a)$ . What is the electrostatic potential at the points  $(0, 0, \pm z)$  and  $(x, y, 0)$ ?

### SOLUTION:

(a) For increasing electric field:

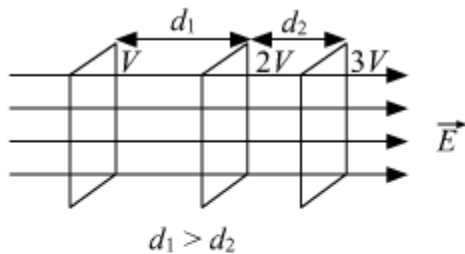

For constant electric field vector E:

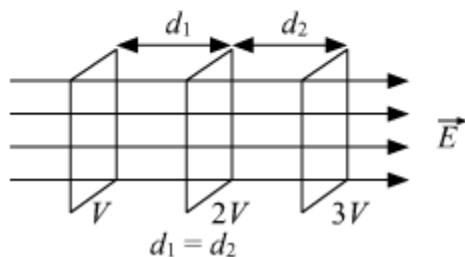

**Difference:** For constant electric field, the equipotential surfaces are equidistant for the same potential difference between these surfaces; while for increasing electric field, the separation between these surfaces decreases, in the direction of the increasing field, for the same potential difference between them.

(b)

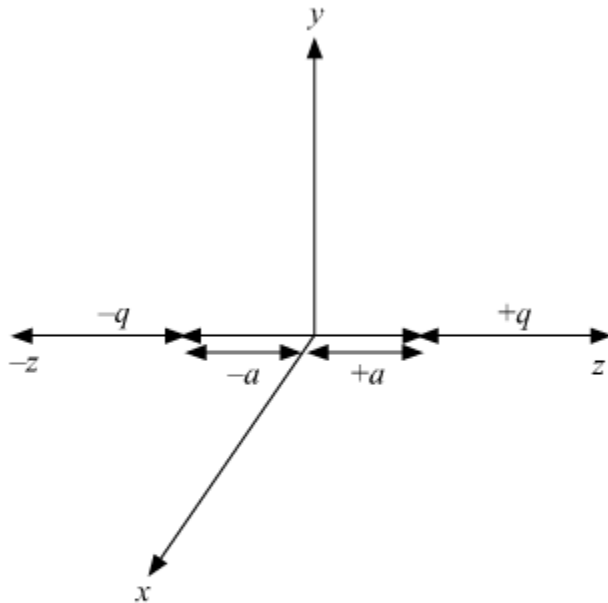

For a point  $(0, 0, \pm z)$

These points will be somewhere on the axial line.

Hence, Potential on the axial line:-

$$V = \pm \frac{P}{4\pi\epsilon_0 r^2}$$

And, for point  $(x, y, 0)$ , This point will be on the equilateral plane:

So,  $V = 0$ .

### Question 16

Using Kirchoff's rules, calculate the current through the  $40 \Omega$  and  $20 \Omega$  resistors in the following circuit:

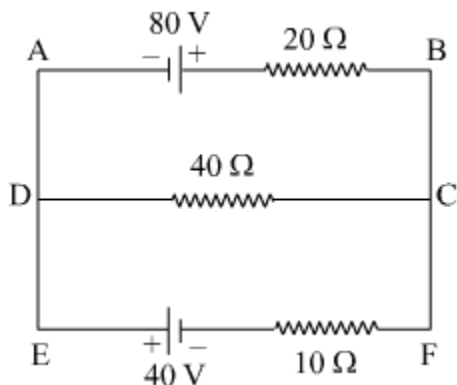

OR

What is end error in a metre bridge? How is it overcome? The resistances in the two arms of the metre bridge are  $R = 5 \Omega$  and  $S$  respectively.

When the resistance  $S$  is shunted with an equal resistance, the new balance length found to be  $1.5 l_1$ , where  $l_1$  is the initial balancing length. Calculate the value of  $S$ .

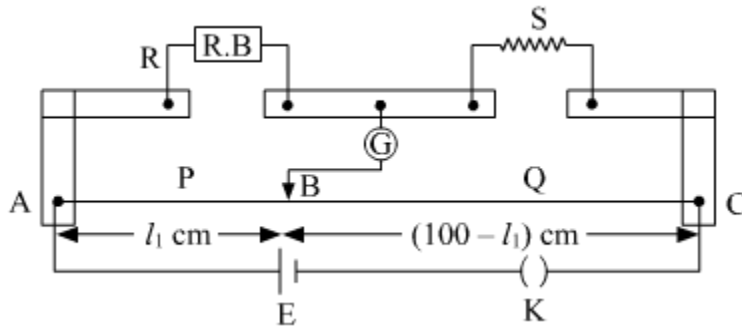

**SOLUTION:**

Apply KVL through ABCDA:

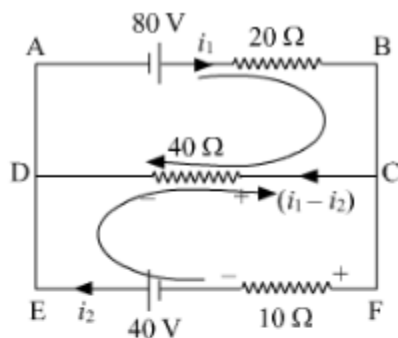

$$80 - 20i_1 - 40(i_1 - i_2) = 0$$

$$80 - 60i_1 + 40i_2 = 0 \quad \text{equation (1)}$$

Apply KVL through FEDCF:

$$40 + 40(i_1 - i_2) - 10i_2 = 0$$

$$40 + 40i_1 - 50i_2 = 0 \quad \text{equation (2)}$$

$$4i_2 - 6i_1 = -8 \quad \text{equation (1)}$$

$$-5i_2 + 4i_1 = -4 \quad \text{equation (2)}$$

Multiplying equation (2) by  $\frac{6}{4}$  and add with equation (1)

$$\begin{array}{r} 4i_2 - 6i_1 = -8 \\ -\frac{30i_2}{4} + 6i_1 = -6 \\ \hline 4i_2 - \frac{30}{4}i_2 = -14 \end{array}$$

$$\frac{-14}{4}i_2 = -14, i_2 = \frac{-14}{7} \times 2$$

$$i_2 = 4 \text{ A}$$

Put the value of  $i_2$  in equation (1)

$$4 \times (4) - 6i_1 = -8$$

$$16 - 6i_1 = -8$$

$$6i_1 = 16 + 8 = 24$$

$$i_1 = 4 \text{ A}$$

$$\begin{aligned} \text{So, current through } 40 \Omega \text{ resistor} &= i_1 - i_2 \\ &= 4 - 4 \\ &= 0 \text{ A} \end{aligned}$$

Current through  $20\Omega$  resistor = 4 A

**OR**

The shifting of zero of the scale at different points as well as the stray resistance gives rise to the end error in meter bridge wire. This error arises due to the non-uniformity of the meter wire. End corrections can be estimated by including known resistances  $P_1$  and  $Q_1$  in the two ends and finding the null point

We have

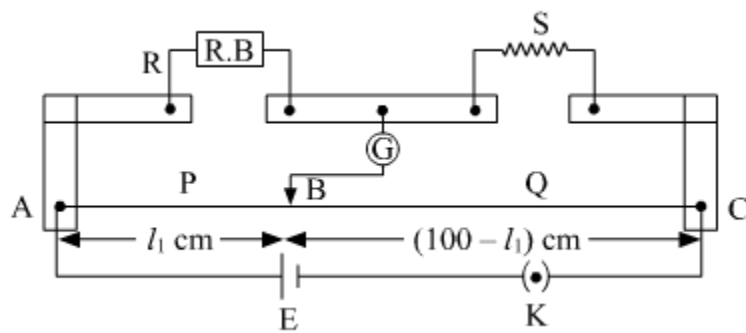

$$R = 5 \Omega$$

According to the wheat stone Bridge principle:

$$\frac{R}{l_1} = \frac{S}{100-l_1}$$

$$\frac{5}{l_1} = \frac{S}{100-l_1} \text{ equation (1)}$$

After shunting means we are connecting resistance in parallel:-

$$S \rightarrow \frac{S}{2}$$

$$\frac{5}{1.5l_1} = \frac{S}{2(100-1.5l_1)} \text{ equation (2)}$$

Equation (1) can be written as:

$$500 - 5l_1 = Sl_1 \text{ equation (3)}$$

And, equation (2) can be written as

$$10(100 - 1.5l_1) = 1.5Sl_1 \text{ equation (4)}$$

From equation (3) and (4)

$$\frac{500-5l_1}{l_1} = \frac{1000-15l_1}{1.5l_1}$$

$$750 - 7.5l_1 = 1000 - 15l_1$$

$$-250 = -7.5l_1$$

$$l_1 = \frac{100}{3}$$

$$S = \frac{500 - \frac{5 \times 100}{3}}{\frac{100}{3}} = \frac{500 - \frac{500}{3}}{\frac{100}{3}} = \frac{1000}{3} \times \frac{3}{100}$$

$$S = 10 \Omega$$

### Question 17

(a) Write the relation between half life and average life of a radioactive nucleus.

(b) In a given sample two isotopes A and B are initially present in the ratio of 1 : 2.

Their half lives are 60 years and 30 years respectively. How long will it take so that the sample has these isotopes in the ratio of 2 : 1?

### SOLUTION:

Half-life and Average life of a radioactive nucleus are related as,



Half Life = Mean life(Average Life)  $\times \ln 2$

(b) According to relation,  $N = N_0 e^{-\lambda t}$

For given isotopes A and B, we can write,

$$N_A = N_0 e^{-\lambda_A t_A}$$

$$N_B = 2N_0 e^{-\lambda_B t_B}$$

let at the time 't',  $N_A : N_B = 2 : 1$ ,

$$(N_0 e^{-\lambda_A t}) = 4N_0 e^{-\lambda_B t}$$

$$\Rightarrow e^{-(\lambda_A - \lambda_B)t} = 4$$

$$\Rightarrow -(\lambda_A - \lambda_B)t = 2 \ln 2$$

$$\Rightarrow -\left(\frac{\ln 2}{t_{(1/2)A}} - \frac{\ln 2}{t_{(1/2)B}}\right)t = 2 \ln 2$$

$$\Rightarrow -\left(\frac{1}{60} - \frac{1}{30}\right)t = 2$$

$$\Rightarrow t = 120 \text{ years}$$

### Question 18

Define the term wavefront. Using Huygen's wave theory, verify the law of reflection.

OR

Define the term, "refractive index" of a medium. Verify Snell's law of refraction when a plane wavefront is propagating from a denser to a rarer medium.

### SOLUTION:

A wavefront is defined as the locus of all points having the same phase at a given instant of time.

### Derivation of Law of reflection:

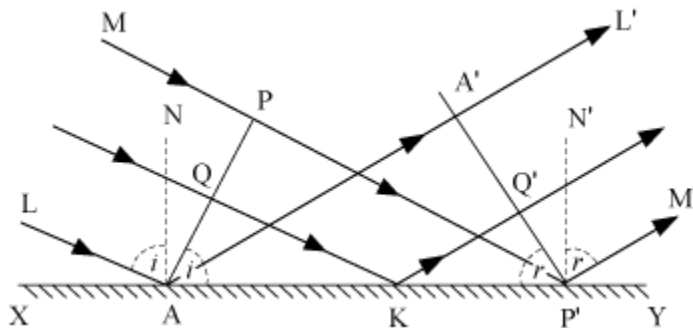

Consider any point Q on the incident wavefront PA.

When the disturbance from P on incident wavefront reaches point P', the disturbance from point Q reaches Q'.

If c is the velocity of light, then the time taken by light to go from point Q to Q'(via point K) is given by,

$$t = \frac{QK}{c} + \frac{KQ'}{c} \quad \dots(i)$$

In right-angled  $\Delta AQK$ ,  
 $\angle QAK = \angle i$

$$\therefore QK = AK \sin i$$

In right-angled,  $\Delta KQ'P'$   
 $\angle Q'P'K = r$

$$\therefore KQ' = KP' \sin r$$

Substituting these values in equation (1),

$$t = \frac{AK \sin i}{c} + \frac{KP' \sin r}{c}$$

$$t = \frac{AK \sin i + (AP' - AK) \sin r}{c} \quad (\because KP' = AP' - AK)$$

$$t = \frac{AP' \sin r + AK (\sin i - \sin r)}{c} \quad \dots(ii)$$

The rays from different points on incident wavefront will take the same time to reach the corresponding points on the reflected wavefront, if 't' given by equation (ii) is independent of AK.

$$\therefore AK (\sin i - \sin r) = 0$$

$$\sin i - \sin r = 0$$

$$\sin i = \sin r$$

$$i = r$$

i.e., the angle of incidence is equal to the angle of reflection.

Also, the incident ray (LA or MP'), reflected ray (AA'L' or P'M'), and the normal (AN) - all lie in the same plane.

**OR**

Refractive index of a medium may be defined as the ratio of the speed of light in air and the speed of light in the given medium. It doesn't have a unit.

Refraction On The Basis Of Wave Theory

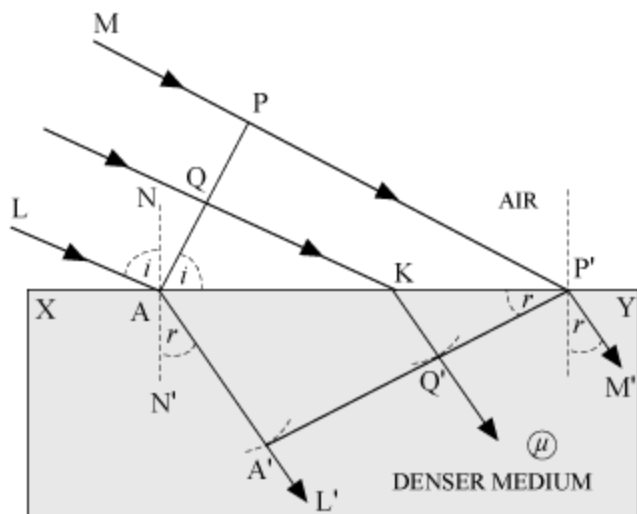

Consider any point Q on the incident wavefront.

Suppose when disturbance from point P on incident wavefront reaches point P' on the refracted wavefront, the disturbance from point Q reaches Q' on the refracting surface XY.

Since P'A' represents the refracted wavefront, the time taken by light to travel from a point on incident wavefront to the corresponding point on refracted wavefront should always be the same. Now, the time taken by light to go from Q to Q' will be

$$t = \frac{QK}{c} + \frac{KQ'}{v} \quad \dots(i)$$

In right-angled  $\Delta AQK$ ,  $\angle QAK = i$

$$\therefore QK = AK \sin i \quad \dots (ii)$$

In right-angled  $\Delta P'Q'K$ ,

$$\angle Q'P'K = r$$

$$KQ' = KP' \sin r \quad \dots (iii)$$

Substituting (ii) and (iii) in equation (i),

$$t = \frac{AK \sin i}{c} + \frac{KP' \sin r}{v}$$

$$\text{Or, } t = \frac{AK \sin i}{c} + \frac{(AP' - AK) \sin r}{v} \quad (\because KP' = AP' - AK)$$

$$\text{Or, } t = \frac{AP'}{c} \sin r + AK \left( \frac{\sin i}{c} - \frac{\sin r}{v} \right) \quad \dots(iv)$$

The rays from different points on the incident wavefront will take the same time to reach the corresponding points on the refracted wavefront i.e., t given by equation (iv) is independent of AK. It will happen so, if



$$\frac{\sin i}{c} - \frac{\sin r}{v} = 0$$

$$\frac{\sin i}{\sin r} = \frac{c}{v}$$

However,  $\frac{c}{v} = \mu$

$$\therefore \mu = \frac{\sin i}{\sin r}$$

This is the Snell's law for refraction of light.

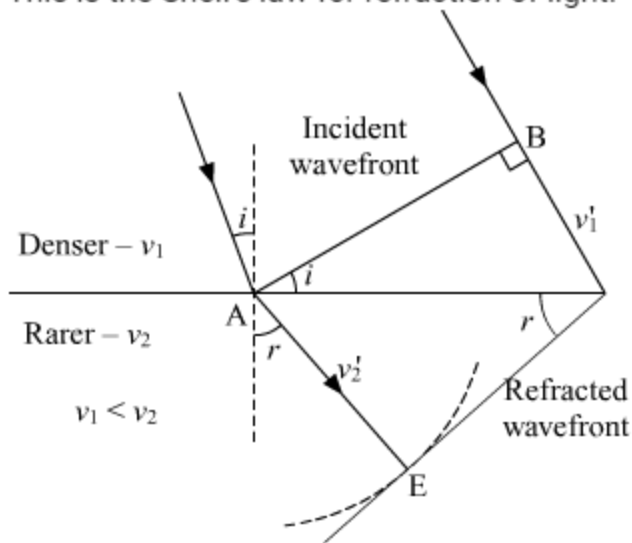

### Question 19

(a) Define the term 'self-inductance' of a coil. Write its S.I. unit.

(b) A rectangular loop of sides  $a$  and  $b$  carrying current  $I_2$  is kept at distance ' $a$ ' from an infinitely long straight wire carrying a current  $I_1$  as shown in the figure. Obtain an expression for the resultant force acting on the loop.

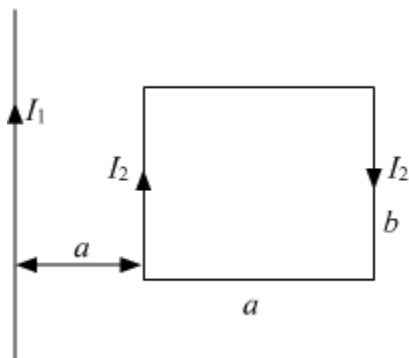

### SOLUTION:

Self-inductance-

$$\phi \propto I$$

Where,

$\phi$ =magnetic flux

I=current flowing

$$\phi = L I$$

where L=coefficient of self-inductance.

When I= 1A

$$\phi = L$$

So, from general understanding, we can say that self-inductance is related to the magnetic flux of a coil when the unit current is flowing through it.

In other words, self-inductance is the emf induced in the coil when the rate of change of current in the coil is 1ampere/second.

S.I. unit of self-inductance is Henry(H).

b.

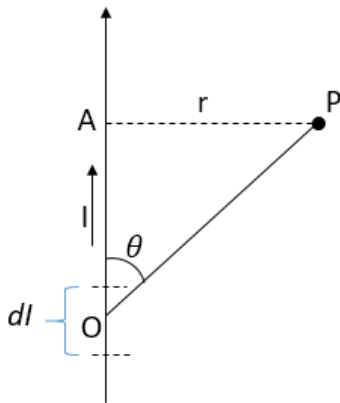

We know the magnetic field due to an infinitely long current-carrying wire is given by

$$B = \frac{\mu_0 i}{2\pi r}$$

where  $\mu_0 = 4\pi \times 10^{-7}$  H/m

$i$  = current carried by infinite wire

$r$  = perpendicular distance of wire to the point

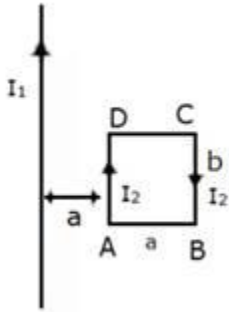

Force on a straight wire is given by,

$$F = i(l \times B)$$

Using right-hand rule, we can find the direction of the magnetic field for  $I_1$ .

According to **Fleming's right-hand rule**, the thumb, forefinger and middle finger of the right hand are stretched perpendicular to each other as shown in the illustration shown below, and if the thumb represents the direction of the movement of conductor, forefinger represents direction of the magnetic field, then the middle finger represents direction of the induced current.

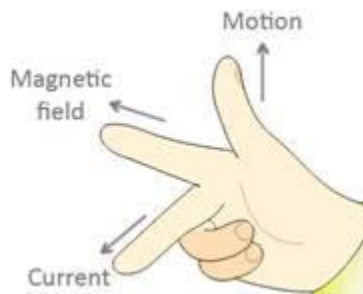

In the square magnetic field is acting in the downward direction.

Now, for side AB  $I$  is  $+y$  direction,  $B$  is downward,  $I \times B$  is in  $x$ -direction and magnitude of the force is,

$$\vec{F} = i(\vec{l} \times \vec{B})$$

$$F = I_2 \left( b \times \frac{\mu_0 I_1}{2\pi r} \right)$$

$$F = \frac{I_1 I_2 \mu_0 b}{2\pi r} \text{ in -ve x-direction.}$$

As for BC and AD forces are equal but opposite in direction so they will cancel out each other.

And for side CD, I is -y-direction, B is downward,  $I_x B$  is in +x direction and magnitude of the force is,

$$\vec{F} = i(\vec{l} \times \vec{B})$$

$$F = I_2 \left( b \times \frac{\mu_0 I_1}{2\pi(2a)} \right)$$

$$F = \frac{I_1 I_2 \mu_0 b}{4\pi a} \text{ in +ve x-direction.}$$

So, net force will be in -ve x-direction,

$$F_{net} = \frac{I_1 I_2 \mu_0 b}{\pi a} \left( \frac{1}{2} - \frac{1}{4} \right)$$

$$F_{net} = \frac{I_1 I_2 \mu_0 b}{4\pi a}$$

### Question 20

(a) Describe briefly the functions of the three segments of n-p-n transistor.

(b) Draw the circuit arrangement for studying the output characteristics of n-p-n transistor in CE configuration. Explain how the output characteristics is obtained.

OR

Draw the circuit diagram of a full wave rectifier and explain its working. Also, give the input and output waveforms.

### SOLUTION:

(a) Three segments of transistor

Emitter – Segment is on one side of the transistor. It is of moderate size and heavily doped. It supplies a huge number of majority carriers for the current flow through the transistor.

Base – It is the central segment. It is very thin and lightly doped.

Collector – It collects a major portion of the majority carrier supplied by the emitter. It is moderately doped and large in size compared to emitter.

(b) Circuit arrangement for studying the output characteristics of n-p-n transistor in CE configuration

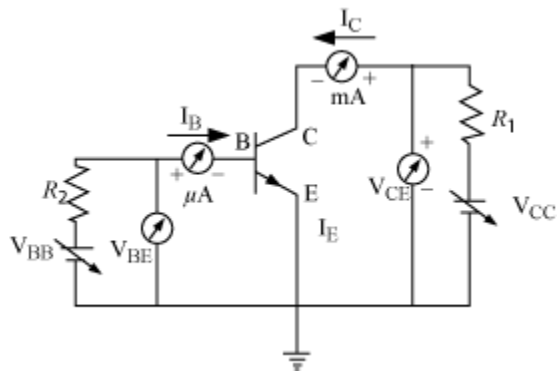

Variation of collector current  $I_C$  with the collector – Emitter voltage  $V_{CE}$  is called output characteristics

### Output characteristics

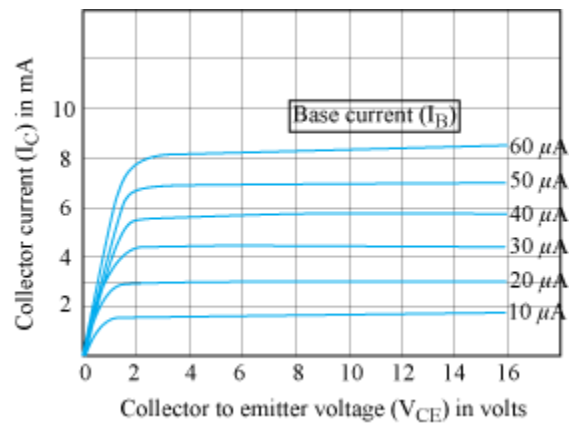

The output characteristics describe the relationship between output current ( $I_C$ ) and output voltage ( $V_{CE}$ ).

First, draw a vertical line and a horizontal line. The vertical line represents y-axis and horizontal line represents x-axis. The output current or collector current ( $I_C$ ) is taken along the y-axis (vertical line) and the output voltage ( $V_{CE}$ ) is taken along the x-axis (horizontal line).



To determine the output characteristics, the input current or base current  $I_B$  is kept constant at  $0 \mu\text{A}$  and the output voltage  $V_{CE}$  is increased from zero volts to different voltage levels. For each level of the output voltage, the corresponding output current ( $I_C$ ) is recorded.

A curve is then drawn between output current  $I_C$  and output voltage  $V_{CE}$  at constant input current  $I_B$  ( $0 \mu\text{A}$ ).

OR

### Full-wave rectifier

Two diodes are used to give rectified O/P corresponding to both positive as well as negative half cycles.

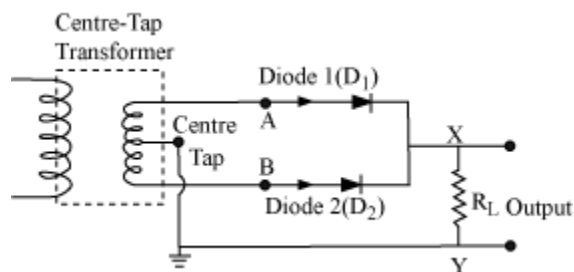

When the voltage at A with respect to the center tap is positive, and the voltage at B is negative. Then,  $D_1$  is forward biased and  $D_2$  is reversed biased. Hence,  $D_1$  conducts and  $D_2$  does not.

When the voltage of A becomes negative, then B becomes +ve. Therefore,  $D_1$  does not conduct and  $D_2$  conducts. Hence, we obtain output voltage during both the positive as well as negative half of the cycle.

Input and Output waveforms are shown below.

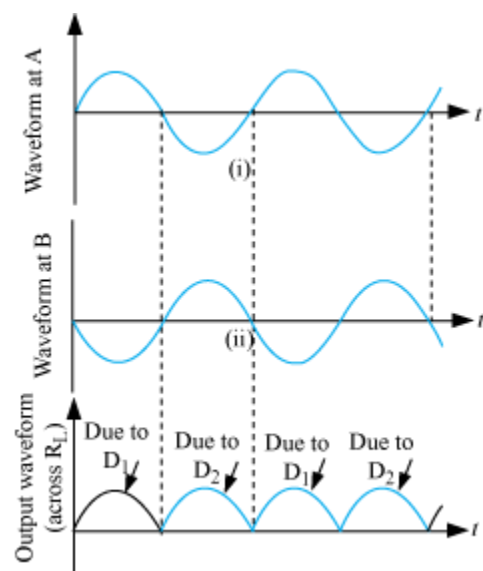

### Question 21

(a) If A and B represent the maximum and minimum amplitudes of an amplitude modulated wave, write the expression for the modulation index in terms of A and B.

(b) A message signal of frequency 20 kHz and peak voltage 10 V is used to modulate a carrier of frequency 2 MHz and peak voltage of 15 V. Calculate the modulation index. Why the modulation index is generally kept less than one?

### SOLUTION:

(a) Modulation index for an AM wave for which the maximum amplitude is 'a' while the minimum amplitude is 'b':

$$\text{Modulation index, } a_m = \frac{E_m}{E_c} \quad \dots (1)$$

$$\text{The maximum amplitude of the modulated wave, } a = E_c + E_m \quad \dots (2)$$

$$\text{The minimum amplitude of the modulated wave, } b = E_c - E_m \quad \dots (3)$$

From equation (2) and (3), we get,

$$E_c = \frac{a+b}{2}, \quad E_m = \frac{a-b}{2}$$

From Equation 1 we get,

$$\text{Modulation index, } a_m = \frac{E_m}{E_c} = \frac{\frac{(a-b)}{2}}{\frac{(a+b)}{2}} = \frac{(a-b)}{(a+b)}$$

(b)  $F_m = 20 \text{ kHz} = \text{Message signal frequency}$

$V_m = 10 \text{ V} = \text{Peak voltage do message signal}$

$F_c = 2 \text{ MHz} = \text{Carrier frequency}$

$V_c = 15 \text{ V} = \text{Peak voltage of carrier signal}$

$$\text{Modulation index} = \frac{V_m}{V_c} = \frac{10}{15} = \frac{2}{3}$$

To avoid distortion, the modulation index is generally kept less than one.

### Question 22

(a) State Gauss's law for magnetism. Explain its significance.

(b) Write the four important properties of the magnetic field lines due to a bar magnet.

OR

Write three points of differences between para-, dia- and ferro- magnetic materials, giving one example for each.

### SOLUTION:

(a) The net magnetic flux ( $\Phi_B$ ) through any closed surface is always zero.

This law suggests that the number of magnetic field lines leaving any closed surface is always equal to the number of magnetic field lines entering it.

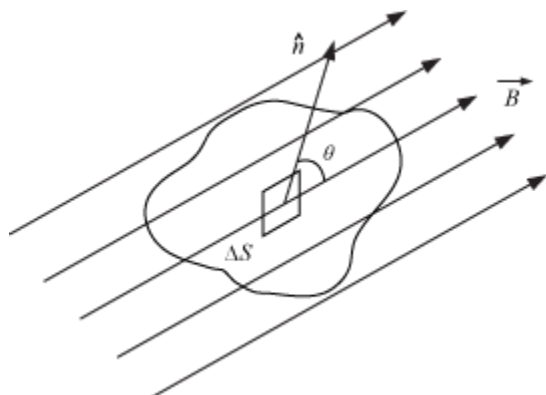

Suppose a closed surface  $S$  is held in a uniform magnetic field  $\vec{B}$ .

Consider a small vector area element  $\Delta\vec{S}$  of this surface.

Magnetic flux through this area element is defined as  $\Delta\phi_B = \vec{B} \cdot \Delta\vec{S}$

Considering all small area elements of the surface, we obtain net magnetic flux through the surface as:

$$\phi_B = \sum_{\text{all}} \Delta\phi_B = \sum_{\text{all}} \vec{B} \cdot \Delta\vec{S} = 0$$

### (b) The four important properties of the magnetic field lines due to a bar magnet.

1. The magnetic field lines of a magnet form continuous closed loops.
2. The tangent to the field line at any point represents the direction of the net magnetic field  $B$  at that point.
3. Larger the number of field lines crossing per unit area, the stronger is the magnitude of the magnetic field  $B$ .
4. The magnetic field lines do not intersect.

OR

#### Ferromagnetism:

These substances are strongly attracted by a magnetic field. Ferromagnetic substances can be permanently magnetized even in the absence of a magnetic field. These substances move (strongly) towards the strong field region when kept a non-uniform external magnetic field. Some examples of ferromagnetic substances are iron, cobalt, nickel, gadolinium

#### Paramagnetism:

The substances that are attracted by a magnetic field are called paramagnetic substances. These substances get magnetized in a magnetic field in the same direction but lose magnetism when the magnetic field is removed. Paramagnetic material moves



(weakly) towards the weak field region when kept a non-uniform external magnetic field. To undergo paramagnetism, a substance must have one or more unpaired electrons.  
Example- O<sub>2</sub>

### Diamagnetism

This is a form of magnetism that is only exhibited by a substance in the presence of an externally applied magnetic field. It is generally quite a weak effect in most materials, although superconductors exhibit a strong effect. Diamagnetic material moves (very weakly) away from strong field region towards the weak field region. Diamagnetic atoms have only paired electrons.

Example- H<sub>2</sub>

### Question 23

(a) Identify the part of the electromagnetic spectrum used in (i) radar and (ii) eye surgery. Write their frequency range.

(b) Prove that the average energy density of the oscillating electric field is equal to that of the oscillating magnetic field.

### SOLUTION:

(a) The microwave range of the electromagnetic spectrum with frequency range 1.6 to 300 GHz and wavelength range 187 to 10 mm are used in operating radar and ultraviolet range with frequency  $8 \times 10^{14}$  Hz to  $3 \times 10^{16}$  Hz and wavelength 400 nm to 10 nm are used in eye surgery.

(b) Energy density in the electric field is

$$U_E = \frac{1}{2} \epsilon_0 E^2$$

Energy density in magnetic field is

$$U_B = \frac{1}{2\mu_0} B^2$$

We know  $E = Bc$

$$c = \frac{1}{\sqrt{\epsilon_0 \mu_0}}$$

$$U_E = \frac{1}{2} \epsilon_0 (cB)^2 = \frac{1}{2} \epsilon_0 \left( \frac{1}{\epsilon_0 \mu_0} \right) B^2 = \frac{B^2}{2\mu_0}$$

now,  $U_E = U_B$

### Question 24

(a) Three photodiodes D<sub>1</sub>, D<sub>2</sub> and D<sub>3</sub> are made of semiconductors having band gaps of 2.5 eV, 2 eV and 3 eV respectively. Which of them will not be able to detect light of wavelength 600 nm?



(b) Why photodiodes are required to operate in reverse bias? Explain.

**SOLUTION:**

(a) Energy of the incident light

$$E = \frac{hC}{\lambda}$$
$$= \frac{(6.6 \times 10^{-34}) \times (3 \times 10^8)}{(600 \times 10^{-9})(1.6 \times 10^{-19})}$$
$$E = 2.06 \text{ eV}$$

The incident radiations can be detected by a photodiode if the energy of incident radiation photon is greater than the band gap. This is true only for D<sub>2</sub> (2 eV). Hence, only D<sub>2</sub> will detect the light of 600 nm wavelength.

(b) The photodiode is reverse biased for operating in the photoconductive mode. As the photodiode is in reverse bias, the width of the depletion layer increases. This reduces the junction capacitance and thereby the response time. In effect, the reverse bias causes faster response times for the photodiode. The photocurrent is linearly proportional to the illuminance.

**Question 25**

(a) Describe any two characteristic features which distinguish between interference and diffraction phenomena. Derive the expression for the intensity at a point of the interference pattern in Young's double slit experiment.

(b) In the diffraction due to a single slit experiment, the aperture of the slit is 3 mm. If monochromatic light of wavelength 620 nm is incident normally on the slit, calculate the separation between the first order minima and the 3<sup>rd</sup> order maxima on one side of the screen. The distance between the slit and the screen is 1.5 m.

OR

(a) Under what conditions is the phenomenon of total internal reflection of light observed? Obtain the relation between the critical angle of incidence and the refractive index of the medium.

(b) Three lenses of focal length +10 cm, -10 cm and +30 cm are arranged coaxially as in the figure given below. Find the position of the final image formed by the combination.

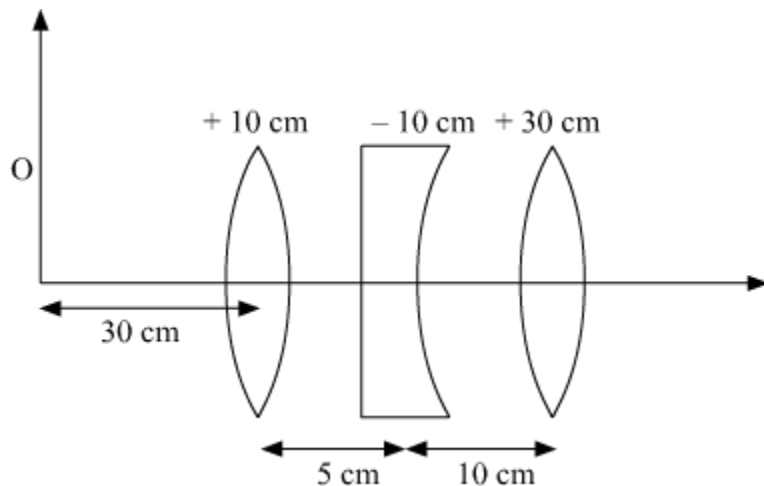

### SOLUTION:

#### (a) Difference between interference and diffraction:

In the interference pattern, the intensity of the dark fringe is completely zero. In the diffraction pattern, the intensity of secondary minima is minimum, but not completely zero.

In interference pattern the width of all the interference fringes is equal. In diffraction pattern the width of central maxima is large, and on increasing distance, the width of maxima decreases.

In interference pattern the intensity of all the bright bands is equal. In the diffraction pattern, the intensity of all the secondary maxima is not equal.

The principle of superposition of light waves: When two or more wave trains of light travelling in a medium superpose upon each other, the resultant displacement at any instant is equal to the vector sum of the displacements due to individual waves.

If  $\vec{y}_1, \vec{y}_2, \vec{y}_3, \dots$  be the displacements due to different waves, then the resultant displacement is given by,  $\vec{y} = \vec{y}_1 + \vec{y}_2 + \vec{y}_3 + \dots$

Conditions for constructive and destructive interference:

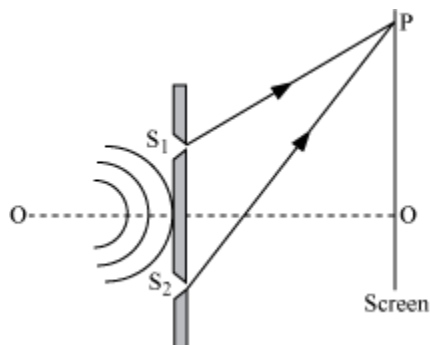

Let the displacement of the waves from the sources  $S_1$  and  $S_2$  at point P on the screen at any time 't' be given by,

$$y_1 = a_1 \sin \omega t$$

and

$$y_2 = a_2 \sin (\omega t + \phi)$$

Where,  $\phi$  is the constant phase difference between the two waves

By the superposition principle, the resultant displacement at point P is given by,

$$y = y_1 + y_2$$

$$y = a_1 \sin \omega t + a_2 \sin (\omega t + \phi)$$

$$= a_1 \sin \omega t + a_2 \sin \omega t \cos \phi + a_2 \cos \omega t \sin \phi$$

$$y = (a_1 + a_2 \cos \phi) \sin \omega t + a_2 \sin \phi \cos \omega t \dots(i)$$

$$\text{Let } a_1 + a_2 \cos \phi = A \cos \theta \quad \dots(ii)$$

$$a_2 \sin \phi = A \sin \theta \quad \dots(iii)$$

Then, equation (i) becomes

$$y = A \cos \theta \sin \omega t + A \sin \theta \cos \omega t$$

$$y = A \sin(\omega t + \theta)$$

Squaring and adding both sides of the equations (ii) and (iii), we obtain

$$A^2 \cos^2 \theta + A^2 \sin^2 \theta = (a_1 + a_2 \cos \phi)^2 + a_2^2 \sin^2 \phi$$

$$A^2 = a_1^2 + a_2^2 (\cos^2 \phi + \sin^2 \phi) + 2a_1 a_2 \cos \phi$$

$$A^2 = a_1^2 + a_2^2 + 2a_1 a_2 \cos \phi$$

The intensity of light is directly proportional to the square of the amplitude of the wave.

The intensity of light at point P on the screen is given by,

$$I = a_1^2 + a_2^2 + 2a_1 a_2 \cos \phi \quad \dots(iv)$$

OR

### (a) TOTAL INTERNAL REFLECTION

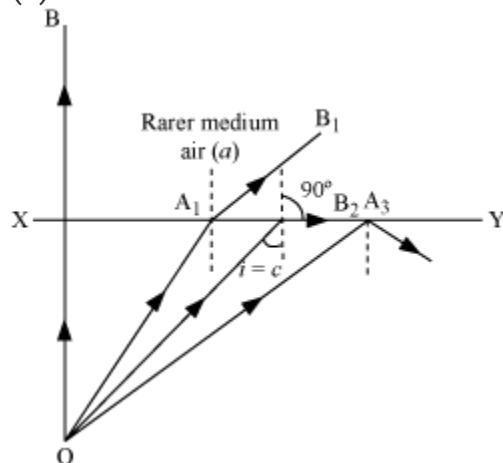

Total internal reflection is the phenomenon of reflection of light into a denser medium from an interface of the denser medium and the rarer medium.

**Two essential conditions for total internal reflection:**

Incident ray should travel in the denser medium and refracted ray should travel in the rarer medium.

The angle of incidence ( $i$ ) should be greater than the critical angle for the pair of media in contact.

**The relation between refractive index and critical angle ( $C$ ):**

When,  $i = C$  and  $r = 90^\circ$ :

Applying Snell's law

$$\mu_b \sin C = \mu_a \sin 90^\circ = \mu_a \times 1$$

$$\frac{\mu_b}{\mu_a} = \frac{1}{\sin C}$$

$${}^a\mu_b = \frac{1}{\sin C}$$

(b)

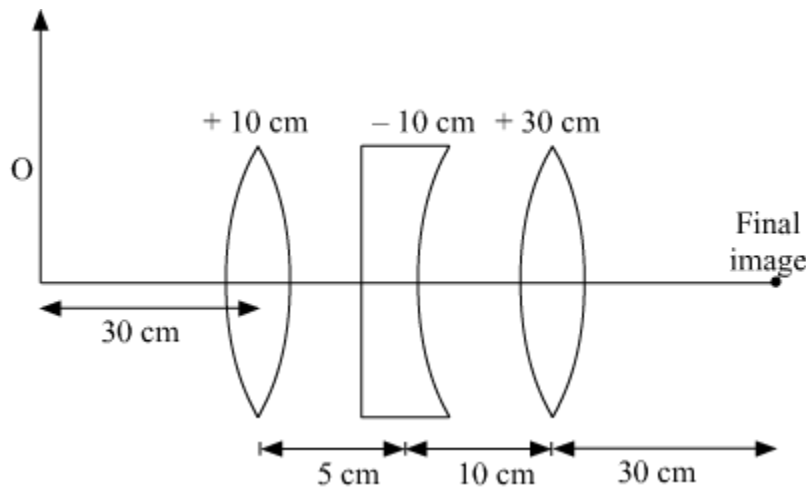



$$\frac{1}{v} - \frac{1}{u} = \frac{1}{f}$$

$$u = -30 \text{ cm}$$

$$f = +10 \text{ cm}$$

$$\frac{1}{v} = \frac{1}{f} + \frac{1}{u}$$

$$\frac{1}{v_1} = \frac{1}{10} - \frac{1}{30}$$

$$\Rightarrow \frac{1}{v_1} = \frac{3-1}{30} = \frac{2}{30}$$

$$v_1 = 15 \text{ cm}$$

$$u = +10 \text{ cm}$$

$$f = -10 \text{ cm}$$

$$\frac{1}{v_2} = \frac{1}{f} + \frac{1}{u} = \frac{1}{10} - \frac{1}{10}$$

$$v_2 = \infty$$

For third lens object is at infinity hence image is formed at focus final image at a distance of 30 cm.

### Question 26

(a) Describe briefly the process of transferring the charge between the two plates of a parallel plate capacitor when connected to a battery. Derive an expression for the energy stored in a capacitor.

(b) A parallel plate capacitor is charged by a battery to a potential difference  $V$ . It is disconnected from battery and then connected to another uncharged capacitor of the same capacitance. Calculate the ratio of the energy stored in the combination to the initial energy on the single capacitor.

OR

(a) Derive an expression for the electric field at any point on the equatorial line of an electric dipole.

(b) Two identical point charges,  $q$  each, are kept 2m apart in air. A third point charge  $Q$  of unknown magnitude and sign is placed on the line joining the charges such that the system remains in equilibrium. Find the position and nature of  $Q$ .

### SOLUTION:

(a) Consider a parallel plate capacitor which is connected across a battery. As soon as the charges from the battery reach one plate, due to insulating gap charge is not able to move further to the other plate. Thus, positive charge is developed at one plate and



negative charge is developed on the other. As the amount of charge increases on the plates a voltage is developed across the capacitor that is opposite to the applied voltage. Hence, the current flowing in the circuit decreases and gradually becomes zero. Thus, the charge is developed on the capacitor.

### Energy Stored in a Charged Capacitor

The energy of a charged capacitor is measured by the total work done in charging the capacitor to a given potential.

Let us assume that initially, both the plates are uncharged. Now, we have to repeatedly remove small positive charges from one plate and transfer them to the other plate.

Let

$q \rightarrow$  Total quantity of charge transferred

$V \rightarrow$  Potential difference between the two plates

Then,

$$q = CV$$

Now, when an additional small charge  $dq$  is transferred from the negative plate to the positive plate, the small work done is given by,

$$dW = Vdq = \frac{q}{C} dq$$

The total work is done in transferring charge  $Q$  is given by,

$$W = \int_0^Q \frac{q}{C} dq = \frac{1}{C} \int_0^Q q dq = \frac{1}{C} \left[ \frac{q^2}{2} \right]_0^Q$$

$$\boxed{W = \frac{Q^2}{2C}}$$

This work is stored as electrostatic potential energy  $U$  in the capacitor.

$$U = \frac{Q^2}{2C}$$

$$U = \frac{(CV)^2}{2C} \quad [ \because Q = CV ]$$

$$\boxed{U = \frac{1}{2} CV^2}$$

(b)

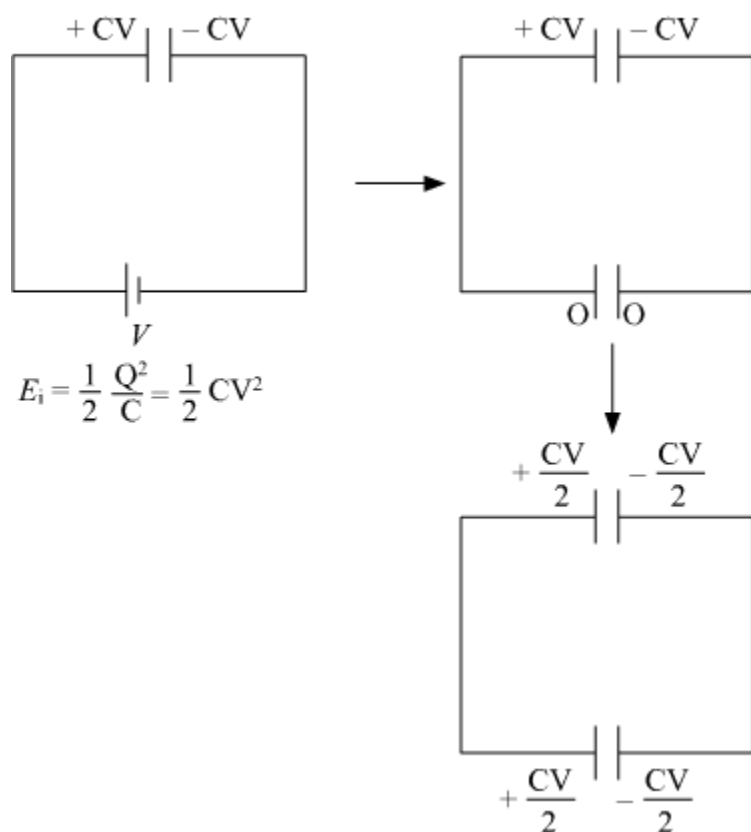

$$E_f = \frac{1}{2} \frac{\left(\frac{CV}{2}\right)^2}{C} + \frac{1}{2} \frac{\left(\frac{CV}{2}\right)^2}{C}$$
$$= \frac{C^2 V^2}{4C}$$

$$E_f = \frac{1}{4} CV^2$$

$$\frac{E_f}{E_i} = \frac{\frac{1}{4} CV^2}{\frac{1}{2} CV^2} = \frac{1}{2}$$

OR

(a) Electric Field for Points on the Equatorial Plane

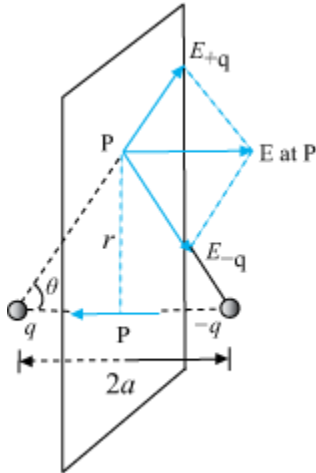

The magnitudes of the electric field due to the two charges +q and -q are given by,

$$E_{+q} = \frac{q}{4\pi\epsilon_0} \frac{1}{r^2 + a^2} \quad \dots(i)$$

$$E_{-q} = \frac{q}{4\pi\epsilon_0} \frac{1}{r^2 + a^2} \quad \dots(ii)$$

$$\therefore E_{+q} = E_{-q}$$

The directions of  $E_{+q}$  and  $E_{-q}$  are as shown in the figure. The components normal to the dipole axis cancel away. The components along the dipole axis add up.

$\therefore$  Total electric field,  $E = -(E_{+q} + E_{-q}) \cos \theta \hat{p}$  [Negative sign shows that the field is opposite to  $\hat{p}$ ]

$$E = -\frac{2qa}{4\pi\epsilon_0(r^2 + a^2)^{3/2}} \hat{p} \quad \dots(iii)$$

At large distances ( $r \gg a$ ), this reduces to,

$$E = -\frac{2qa}{4\pi\epsilon_0 r^3} \hat{p} \quad \dots(iv)$$

$$\therefore \vec{p} = q \times 2a \hat{p}$$

$$\therefore E = \frac{-\vec{p}}{4\pi\epsilon_0 r^3} \quad (r \gg a)$$

(b)

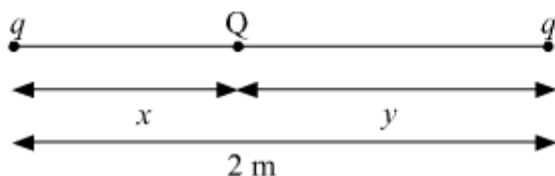

$$\frac{K(q)(Q)}{x} = \frac{-K(q)(q)}{2}$$

$$\Rightarrow Q = \frac{-qx}{2}$$

$$\therefore \frac{KqQ}{x} = \frac{KQq}{y}$$

$$x = y$$

$$x + y = 2$$

$$\therefore x = y = 1$$

$$Q = \frac{-q}{2}$$

### Question 27

(a) In a series LCR circuit connected across an ac source of variable frequency, obtain the expression for its impedance and draw a plot showing its variation with frequency of the ac source.

(b) What is the phase difference between the voltages across inductor and the capacitor at resonance in the LCR circuit?

(c) When an inductor is connected to a 200 V dc voltage, a current of 1 A flows through it. When the same inductor is connected to a 200 V, 50 Hz ac source, only 0.5 A current flows. Explain, why? Also, calculate the self inductance of the inductor.

OR

(a) Draw the diagram of a device which is used to decrease high ac voltage into a low ac voltage and state its working principle. Write four sources of energy loss in this device.

(b) A small town with a demand of 1200 kW of electric power at 220 V is situated 20 km away from an electric plant generating power at 440 V. The resistance of the two wire line carrying power is 0.5  $\Omega$  per km. The town gets the power from the line through a 4000-220 V step-down transformer at a sub-station in the town. Estimate the line power loss in the form of heat.

### SOLUTION:

(a) Consider the following LCR circuit:

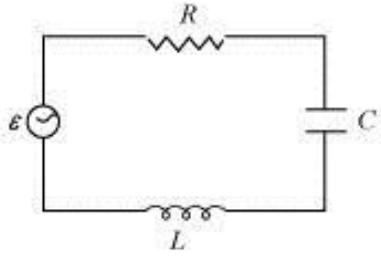

An ac source  $E$  having a voltage of  $v = v_m \sin \omega t$  is applied across the given LCR circuit.

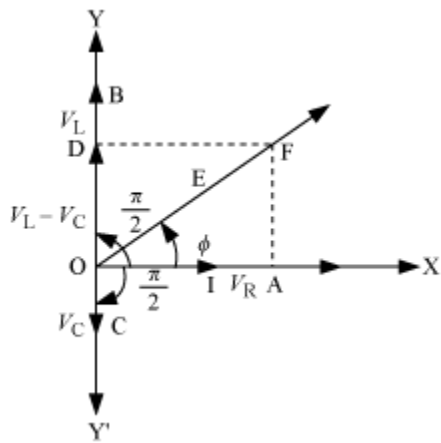

As the inductor, capacitor and the resistor are connected in series so the current through all of them is same (same amplitude and same phase)

Let the current be  $I = I_m \sin \omega t$

The voltage across each component has a different phase relation with the current.

I. Let the maximum voltage across the resistor be  $V_R = I_m R$  that is in the same phase of the current hence it is represented by OA in the phasor diagram.

II. Let the maximum voltage across the inductor be  $V_L = I_m X_L$  and that leads the current by  $\pi/2$ , it is represented by OD in the phasor diagram.

III. Let the maximum voltage across the capacitor be  $V_C = I_m X_C$  and that lags behind the current by  $\pi/2$ , it is represented by OC in the phasor diagram.

Resultant voltage can be found by using the vector sum of the phasors. The resultant voltage is represented by OF.

It can be written as:

$$V_m = \sqrt{V_R^2 + (V_L - V_C)^2} = \sqrt{(I_m R)^2 + (I_m X_L - I_m X_C)^2}$$

$$V_m = I_m \sqrt{R^2 + (X_L - X_C)^2}$$

$$Z = \frac{V_m}{I_m} = \sqrt{R^2 + (X_L - X_C)^2}$$

$$\text{or, } Z = \frac{V_m}{I_m} = \sqrt{R^2 + \left(\omega L - \frac{1}{\omega C}\right)^2}$$

Variation of impedance  $Z$  with frequency  $f$ .

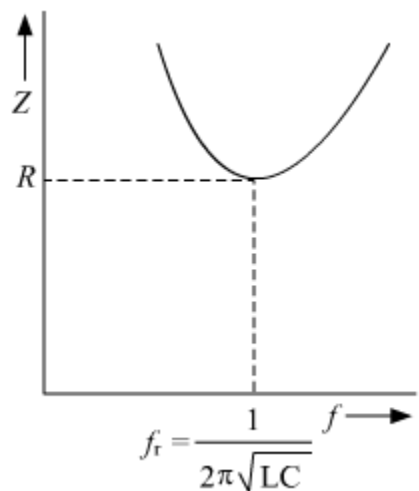

(b) It can be observed from the phasor diagram that the voltage across the inductor leads the current by  $\pi/2$  and that along capacitor leads the current by  $\pi/2$ , so in every situation the phase difference between the inductor and the capacitor is  $\pi$ .

(c) When the inductor is connected across the 200 V DC circuit 1 A current flows because in this case the inductor simply acts as a resistor and there is no inductive reactance. Whereas, when we connect the same inductor across 200 V AC, due to inductive reactance the overall impedance is changed and hence the value of current also changes.

When the inductor is connected across 200 V DC

$$\text{The resistance of the coil } R = \frac{200}{1} = 200 \Omega$$

Let the self-inductance of the inductor be  $L$ ,

When the inductor is connected across 200 V A.C.

$$\text{Net impedance, } Z = \sqrt{(2\pi fL)^2 + R^2} = \frac{200}{0.5} = 400 \Omega$$

$$\Rightarrow (2\pi \times 50 \times L)^2 + 200^2 = 400^2$$

$$\Rightarrow (100\pi L)^2 = 160000 - 40000$$

$$\Rightarrow 10000\pi^2 L^2 = 120000$$

$$\Rightarrow L^2 = \frac{12}{\pi^2}$$

$$\therefore L = \frac{\sqrt{12}}{\pi} \text{ H}$$

OR

(a) A transformer is a device that is used to either increase or decrease the ac voltage level. In order to decrease the high ac voltage level into a low ac voltage level we need a step-down transformer, whose diagram is as follows:

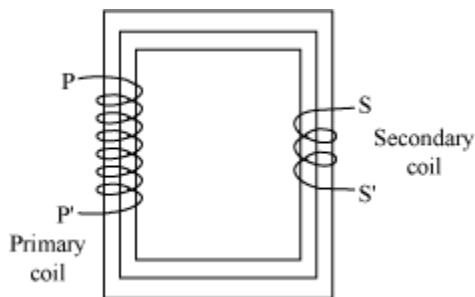

### Step-down transformer

**Working Principle:** A transformer works on the principle of electromagnetic induction. Alternating current in primary coil produces a changing magnetic flux due to this an induced current is set up in the secondary coil.

Losses in a transformer:

- Copper loss – The windings of the transformer have finite resistance due to which some energy is lost in the form of heat. It can be diminished using thick copper wires.



- Iron loss – Loss is in the bulk of iron core due to the induced eddy currents in the iron core. It is minimized by using a thin laminated core.
- Hysteresis loss – Alternating magnetizing and demagnetizing of the iron core causes the loss of energy in the form of heat. It is minimized using a special alloy of the iron core with silicon that has low hysteresis loss.
- Magnetic loss – All the magnetic flux due to the primary coil does not pass through the secondary coil. So there is some leakage of flux. This loss can be minimized by winding primary over the secondary coil.

(b) Total electric power required,  $P = 1200 \text{ kW} = 1,200 \times 10^3 \text{ W}$

Supply voltage,  $V = 220 \text{ V}$

Voltage at which electric plant is generating power,  $V' = 440 \text{ V}$

Distance between the town and power generating station,  $d = 20 \text{ km}$

Resistance of the two-wire lines carrying power =  $0.5 \text{ } \Omega/\text{km}$

Total resistance of the wires,  $R = (20 + 20)0.5 = 20 \text{ } \Omega$

A step-down transformer of rating 4000-220 V is used in the sub-station.

Input voltage,  $V_1 = 4000 \text{ V}$

Output voltage,  $V_2 = 220 \text{ V}$

Rms current in the wire lines is given as:

$$I = \frac{P}{V_1} = \frac{1200 \times 10^3}{4000} = 300 \text{ A}$$

$$\text{Line power loss} = I^2 R$$

$$= (300)^2 \times 20$$

$$= 1,800 \times 10^3 \text{ W}$$

$$= 1,800 \text{ kW}$$